

The following paper was Presented at the 3rd IEA Workshop on Underground Coal Gasification, Brisbane, Australia, November 7 & 8, 2013

## **Underground Coal Gasification (UCG), its potential and its challenges**

**Dr. Mike Clarke, FIEAust, CPEng**

Email: [michael.clarke@metts.com.au](mailto:michael.clarke@metts.com.au)

**Dr. Duncan Seddon, FRACI, CChem,**

Email: [seddon@ozemail.com.au](mailto:seddon@ozemail.com.au)

Coal is widely available in most parts of the world. Underground Coal Gasification (UCG) gives the promise of turning many poor quality coal resources into exploitable reserves by delivering energy in the form of synthesis gas – carbon monoxide and hydrogen, potentially at very low cost. The synthesis gas can be used for generation of electricity and the production of fuels and chemicals by commercially proven technology. Furthermore, any carbon present in the synthesis gas not used for downstream products could be easily separated and geo-sequestered. This could extend the Fossil Fuel Age by providing low cost energy for developing and developed countries alike.

Unfortunately, as Australian experience has shown, UCG also comes with technical and environmental challenges that are still not fully resolved. These challenges have stalled the rapid take-up of UCG technology with some proponents leaving the field.

Underground Coal Gasification (UCG) as a source of synthesis gas (syn-gas) for power generation, liquid fuels production and/or chemicals and fertiliser manufacture has been made to look beguilingly simple and straightforward by many of its proponents. Simple figures, such as below, are produced to introduce the concept to the public, potential investors and the greater scientific and engineering community with UCG technology being promoted as being the path to the monetisation of ‘unminable’ coal where mining cost, technology and/or environmental challenges are too great for other exploitation options.

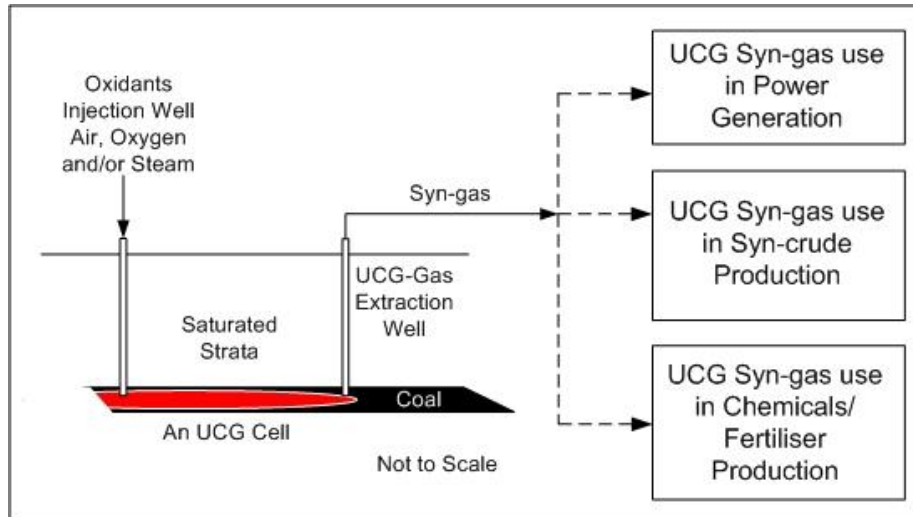

UCG has also been promoted as being a technology that provides a means of monetising coal where all wastes are safely locked-away in underground caverns formed during UCG production; such claims have not always been achieved however with ‘leaks’ from some burns being recorded. Systems need to be developed for ensuring tight well casings in the overlying strata that will not allow syn-gas and waste leaks through heating and cooling with resultant expansion and contraction of casings and fracturing of strata.

The basis of the technology is simple, that being to ignite a coal seam in a controlled manner and extract the partially oxidised/distilled products such that they can be used for chemical or liquid fuels synthesis or combustion purposes. The technology relies on the active fire zone being ‘encased’ in saturated strata well below the water-table such that the migration of combustion products, including many toxic substances, is prevented. The question of how well is the process can be controlled remains to be answered.

### **The Real Maturity of UCG Technology**

Has UCG been successfully commercially demonstrated? Answer: in very basic way.

In Angren, Uzbekistan, UCG is used to auxiliary gaseous fuel to a coal fired power station. In this instance the UCG syn-gas undergoes minimal cleaning. In effect what is being produced is a low Specific Energy (SE) ‘producer gas’ with the SE reportedly being as low as 5 MJ/scm (this being an air blown system). Another significant demonstration of co-firing coal and UCG syn-gas is being undertaken at the Majuba power station, South Africa.

Has UCG technology been used to produce electricity by direct firing into gas turbines, or for chemical and fertiliser manufacture on a commercial scale? To the best of the knowledge of the authors, NO!

For undertaking more advanced utilisation of UCG-gas, three essential features must be established, these being the production of, a consistent flow of gas, at a consistent composition (and specific energy) and with all major impurities removed.

## Towards Maturing UCG

The development of syn-gas cleaning systems that can produce a clean syn-gas suitable for each specific process over a long production period is required. The tars, ash, moisture and sulphur compounds will need to be stripped from the raw gas to facilitate safe storage, transport and use.

The coalfield UCG infrastructure including multiple operational UGC cells and stand-by cells will need to be capable of supplying a consistent flow of gas, even if flame-outs occur through any cause. The product from the multiple cells will need to be blended for producing a gas feed with consistent combustion characteristics and/or carbon monoxide to hydrogen ratios for product synthesis. Some UCG-gas storage will be required for this blending, averaging of constituents, quality monitoring and as insurance against sudden system failures in raw gas production. Also systems for the safe disposal of contaminated solids and liquids that come to the surface as part of the syn-gas flow will need to be in place, here reinjection of wastes into closed cells could be contemplated if the security of those wastes can be guaranteed.

## Technology for Maturing UCG

The challenges of gas clean-up and consistency of flow and quality must be met. Between the UCG extraction well-head and the commercialisation process, some major technology items and processes are required; these come at a cost and with process risk.

Intended Use	Cost	Process Risk
Co-firing Coal Fired Power Stations	Low to Moderate	Low to Moderate
Firing Dedicated Gas Turbine Power Stations	Moderate to High	Moderate to High
Chemicals and Fertiliser requiring Catalysts	High to Very High	High to Very High

In the figure below suggestions for managing UCG syn-gas are presented.

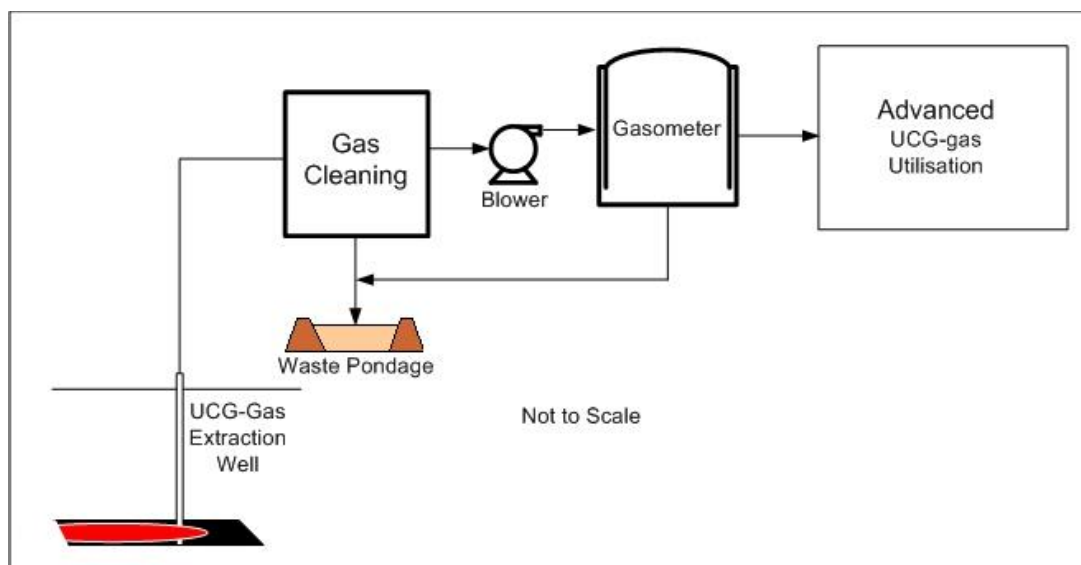

The processes selected for gas cleaning will be chosen for their compatibility with the proposed end use, and may include wet scrubbing, filtration and electrostatic precipitation. In the figure above a gasometer (gasholder) is shown. This is very mature technology that is

likely to be a very necessary component of a UCG-gas utilisation train. The gasometer will have four functions, these being, gas storage, gas averaging, secondary cleaning and as a sampling point. Also shown in the figure is a waste pond. This pond will contain particulates, chemicals (including aromatic hydrocarbons) and contaminated water, but could its contents be pumped into closed UCG cells? Note: The pond may be required to be registered as a toxic waste facility in some jurisdictions and sound UCG wastes management will be a major factor in the overall acceptance of UCG as a safe way of utilising coal.

In the next section, a detailed discussion of what is required for syn-gas cleaning is presented. The level of cleaning will however be related to the intended use, with gas turbine technology requiring a marginally less stringent cleaning regime than sensitive catalyst based production systems.

### **3.0 The Realities of Cleaning UCG Syn-gas**

Syn-gas, which is a mixture of carbon monoxide and hydrogen, is produced by underground coal gasification. The syn-gas produced has a wide range of compositions which depends on the method of underground gasification in use, such as whether the gasification uses air, oxygen enriched air or oxygen, and local parameters, such as the amount of water and the salinity of water present in the underground gasifier.

Downstream processes which use syn-gas fall into two groups. In the first group are methods which utilise the heat content of the syn-gas. This group comprised combustion processes which burn the syn-gas to form carbon dioxide and water. In the second group are chemical processes which utilise either or both of the components of syn-gas for a chemical reaction. These chemical processes use catalysts which are very sensitive to foreign material.

Syn-gas gas produced from underground coal gasification contains contaminants which preclude it from being immediately used for downstream processes. In general these contaminants are:

- Particulate matter - mineral dust and soot from incomplete combustion which can cause fouling in downstream equipment,
- Heavy hydrocarbons and tars which can foul downstream equipment,
- Carbon dioxide which reduces the heat content of the gas and acts as poison to some catalytic processes,
- Nitrogen from air combustion, air ingress and from the coal. Nitrogen reduces the heat content of the synthesis gas and inhibits some catalysts,
- Oxygen from air ingress or poor combustion control. Oxygen can potentially result in explosive mixtures, is a poison to catalysts and causes unwanted side-reactions leading to catalyst fouling,
- Sulphur compounds which produce unacceptable sulphurous emissions on combustion and is generally poisonous to catalysts,

- Chlorine and chlorine compounds from coal and saline water. These corrode downstream equipment and are catalyst poisons, and
- Trace heavy metals from the coal, such as mercury and arsenic, which act as a poison to catalysts and can result in unacceptable emissions from combustion processes.

Clearly it is important to minimise these contaminants by judicious operation of the gasifier. Some of the potential contaminants may not be an issue for a particular location.

Generally combustion processes are more tolerant of contaminants than chemical conversion. A comparison of the gas composition for a typical oxygen blown UCG gasifier compared to a high temperature surface gasifier is shown in Table 2; the surface gasifier example is a high temperature entrained-bed type.

Table 2: Syngas composition (vol.%) of underground and surface gasifier [1].

Syn-gas Constituent	UCG	Surface Gasifier
Hydrogen	30.2	36.0
Carbon Monoxide	17.4	52.5
Carbon Dioxide	32.6	10.0
Methane	18.2	0.0
Nitrogen	0.1	1.1
Tar	0.1	0.0
Hydrogen sulphide and COS	0.2	0.4
C <sub>2+</sub>	0.9	0.0
Totals	99.7	100
[H <sub>2</sub> +CO]	47.6	88.5
BTU/scf	356	286
MJ/scm	13.3	10.7

The data illustrates the following points:

1. Carbon dioxide is high compared to the surface gasifier. One consequence is that the valuable syn-gas components [H<sub>2</sub> + CO] are much lower in the UCG product,
2. Methane concentration is high for UCG and absent in the surface gasifier. A consequence of this is that the calorific value of the UCG product is higher than that for the surface gasifier. However, methane is inert in most chemical operations, adding to processing costs,
3. The nitrogen level is slightly higher in the surface gasifier due to the use of nitrogen to transport coal into the gasifier unit,
4. The UCG gasifier contains significant amounts of tar and C<sub>2+</sub> components which are absent from the surface gasifier synthesis gas, and
5. Both systems produce hydrogen sulphide and carbonyl sulphide. Also not shown is that both would produce trace amounts of ammonia and hydrogen cyanide.

### 3.1 Clean-up for combustion processes

The main concern is particulate matter including tars. The clean-up would include a water-wash scrubber system. This would have the duty to remove particulate mineral matter and condensed tar products. Coal tars and coal naphtha in the scrubber water may require removal by solvent extraction processes such as PhenoSolvan™.

Following the scrubber, cooling would remove excess water prior to compression and reticulation to the combustion operation. Depending on the local requirements it may be necessary for a combustion process to ensure minimum sulphur emissions which would require removal of all or at least a major part of the sulphur compounds. There are several options for this [2]. These could be based on simple iron oxide or zinc oxide adsorption systems or simple wash systems that are specific for hydrogen sulphide (e.g. Stretford Process). More complex systems for total sulphur removal are discussed in the next section.

### 3.2 Clean-up for chemical processing

As well as particulate removal, chemical processing generally requires a unit operation to adjust the syn-gas stoichiometric ratio ( $[H_2]/[CO]$ ), usually by means of the water-gas-shift process, and the removal of excess carbon dioxide. Furthermore, it is usually required to remove all sulphur compounds to below 1ppm. This is accomplished along with the removal of carbon dioxide in an acid gas removal plant.

It should be noted that the composition of UCG syn-gas may change with time-on-stream (over hours for instance). Such changes can be detrimental to downstream process operations and some sort of buffering would be required. This suggests a gasometer or similar buffer into the process flow to help smooth out changes in composition.

For ease of description, we consider the case for the production of highly purified syn-gas. The first step is the removal of particulate matter and heavy tars using a water scrubber system. This is followed by the water-gas-shift (WGS) section to adjust the gas stoichiometric ratio.

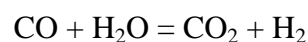

To reduce the size of the plant (and other units downstream), this unit operation is best conducted at pressure and so a compression stage is included prior to WGS. The high temperature WGS unit is robust to many poisons and contaminants but requires the process gas heated to about 350°C requiring the diversion of some of the produced gas to an appropriate heater.

Following WGS, the shifted gas is cooled and passed to the COS converter with the duty to convert the traces of carbonyl sulphide present into hydrogen sulphide:

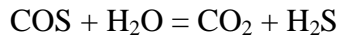

Substantially all of the sulphur is now present as hydrogen sulphide and the gas is passed to an acid gas plant which removes the acid gases hydrogen sulphide and carbon dioxide either as separate or combined streams. There are many process operations for this. However, conventional wisdom is that for treating gases, which might contain hydrocarbons (coal tar naphtha) which have passed through the WGS operation, solvent processes such as Rectisol™ are superior to amine based systems.

Treating the hydrogen sulphide off-gas requires a Claus or similar unit to convert the hydrogen sulphide to sulphur for disposal. To-date carbon dioxide off-gas has been exhausted to atmosphere but in future carbon dioxide geo-sequestration may be required.

At this stage the syn-gas is reasonably pure. Further purification may be required to remove the last vestiges of sulphur (zinc oxide absorber) and a polishing operation (carbon absorbers) to ensure that trace volatile poisons (such as mercury, arsine) are removed. A drier is included to remove any water that may be inimical to downstream processes. A typical process flow sheet is shown in the figure.

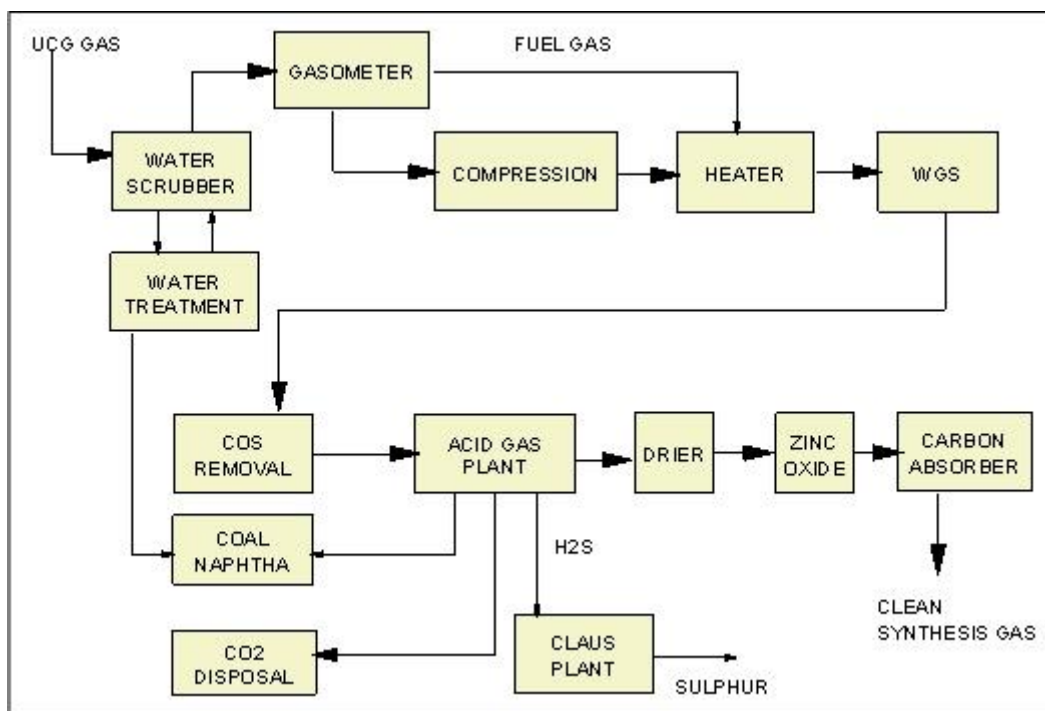

Figure 3. UCG-Syn-gas Clean-up

The principal driver for UCG is the potential low cost of syngas production. The clean up requirements are indicative of a high processing cost for the UCG syn-gas, potentially effectively doubling the cost of the gas to a downstream user. However, relative to natural gas prices in most parts of the world, especially in Europe, the cost will still be well below alternative feedstock options.

#### 4. Managing UCG-gas to Achieve the Highest Use of Available Raw Energy

In Table 2, it can be seen that the methane content of the UCG syn-gas is 18%, and represents around 50% of the syn-gas energy content. This methane cannot be directly utilised in the synthesis reactions, e.g. Fischer-Tropsch or methanol, that produce liquid fuels; it needs to be put through a reformer to produce additional hydrogen and carbon monoxide, as shown in Figure 4a.

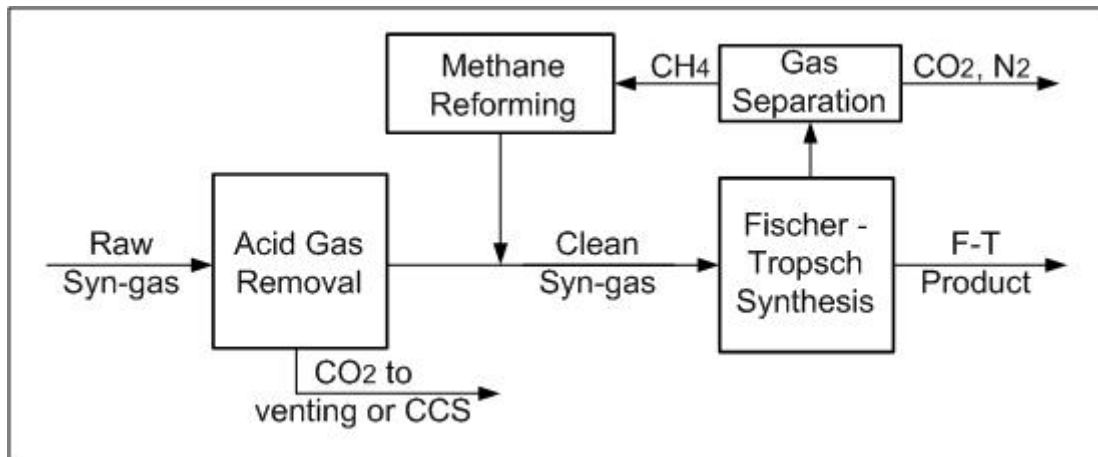

Figure 4a. Syn-gas Methane Reforming

Alternatively in a simplified process, there is no methane reforming (or gas recycling) and the syn-gas off-gas is used for power generation, Figure 4b.

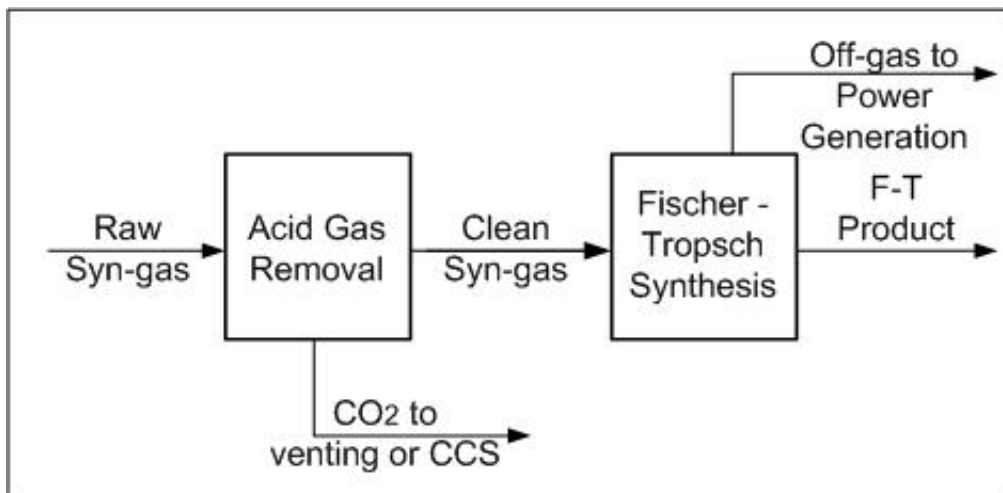

Figure 4b. Off-gas to Power Generation

The choice of which route is best for maximising returns from syn-gas will be dependant on local circumstances, especially the need for and price of electricity.

Figures 4a and 4b also suggest that a portion of the carbon dioxide generated in the UCG cells could be sent to Carbon Capture and Storage (CCS). The feasibility of CCS will depend



on the availability of suitable carbon storage opportunities and on the economics of carbon, that being carbon taxes and imposts versus the cost of CCS. Note: CCS and UCG are a story to be told at another occasion.

## **5. The Scale and Costs of UCG Developments**

Industry wisdom has settled on future major UCG developments having outputs of >50,000 bbl/day raw synthetic crude production. Some promoters are also looking at smaller units producing less than 10,000 bbl/day to service niche markets, such as the market for diesel in remote mining locations.

We have estimated that for fuels production of about 80,000 to 100,000bbl/d the capital cost of using an above ground coal gasifier would be about \$11.5 billion (US Gulf basis). Using UCG the capital cost would fall to about \$8 billion with proportional savings in operating costs. Thus if the UCG costs are about the same as coal on an energy basis the UCG operation offers a significant advantage over traditional coal gasification routes.

## **6. UCG in an Australian Perspective**

Australia has very extensive proven and recoverable (by accepted mining methods) coal reserves. It also has vast coal resources that are not presently classified as reserves since there are no accepted mining techniques that can give profitable coal extraction. UCG has the potential to allow for vast coal resources to be classified as reserves, if the technology can be proven.

Australia has had many companies interested in promoting UCG technology for their presently un-monetisable coal resources. Some companies, such as Cougar Energy [3] have made mistakes in the management of their UCG trial blocks that have resulted in aquifer contamination. Others have found the regulatory and legislative hurdles too great to continue with specific projects. There are however a number of UCG energy companies who are spending money on researching how to overcome the challenges facing UCG.

The consensus that is developing amongst Australian UCG proponents is that suitable seams (in terms of depth and seam thickness) must be selected, the hydrology of the area must be thoroughly understood, and it is wise to avoid cropping lands when seeking suitable sites for UCG activities.

Selling UCG to the Australian public is becoming more difficult, and this difficulty has been compounded by challenges, relating to aquifer protection, to both the nascent UCG industry and the ever expanding Coal Seam Gas (CSG) industry. Australians, who inhabit the driest inhabited continent, are fearful of threats to the extensive aquifer system that overlies and in some cases is part of the coal measures. The Green movement has also damaged the support

for UCG development, claiming that UCG is intrinsically environmentally unsafe, produces unacceptable high levels of carbon dioxide (see Table 2) and is also opposing UCG developments on the grounds that success will continue the Fossil Fuel Age.

## **7. Conclusion**

UCG technology holds out the promise of providing a means of converting numerous coal resources, equalling trillions of tonnes of coal that presently are economically unrecoverable into viable and verifiable coal resources. It is a technology that could be a major contributor to the continuation Fossil Fuel Age.

Proponents of UCG technology have over simplified the UCG technology story in many instances. The technology has challenges, which relate to producing a consistent gas product in terms of energy content, constituent gases and continuity of production. The product syn-gas also requires very considerable cleaning for advanced uses, cleaning that will be costly in both CAPEX and OPEX.

The technology also has significant environmental challenges, with the containment of wastes produced during the underground gasification process being the major concern. In an Australian context, preventing the contamination of aquifers is a major consideration.

## **8. References**

1. B.E. Davis and J.W. Jennings, J. Pet. Technol., January 1984, p.15
2. S.A. Newman (Ed.), “ Acid and Sour Gas Treating Processes” Gulf Publishing, 1985, gives a good overview of the various approaches to sour (sulphurous) gas treating.
3. ‘Cougar Energy shares down on UCG ban’.  
<http://finance.ninemsn.com.au/newsbusiness/aap/8270821/cougar-energy-shares-down-on-ucg-ban>,  
Sourced, September, 2011

The statements from UCG proponents that fully understood and controllable UCG systems already exist need to be further validated before UCG can be a reality in advanced power generation (using gas turbines) and chemical/fertiliser production. The maturity of UCG systems needs to be verified to make those systems more ‘bankable’. What can be now stated is that co-firing of coal fired power stations is an understood technological application of UCG-gas. Indeed if the UCG cells fail, then coal feed can be increased to compensate for loss of raw energy feed, and that little UCG-gas cleaning is needed, whilst variations in UCG-gas SE can be compensated by varying coal feed and the thermal inertia of the power generation plant.